



# Atlas Double Traffic Guardrail+

Developed specifically for airports with input from the British Airports Authority, Atlas Guardrails provide the ultimate in safety and protection for demanding conditions and large operations.

Designed to be highly resilient to the toughest of climates and with the strongest tolerance to impact damage, this dual-function solution physically segregates and shields walkways from vehicles to keep pedestrians safe and out of danger.

Able to withstand repeated impacts from the largest of workplace vehicles, Atlas Guardrails are ideal for any heavy-duty environment requiring unrivalled safety.

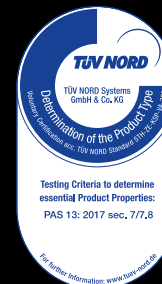

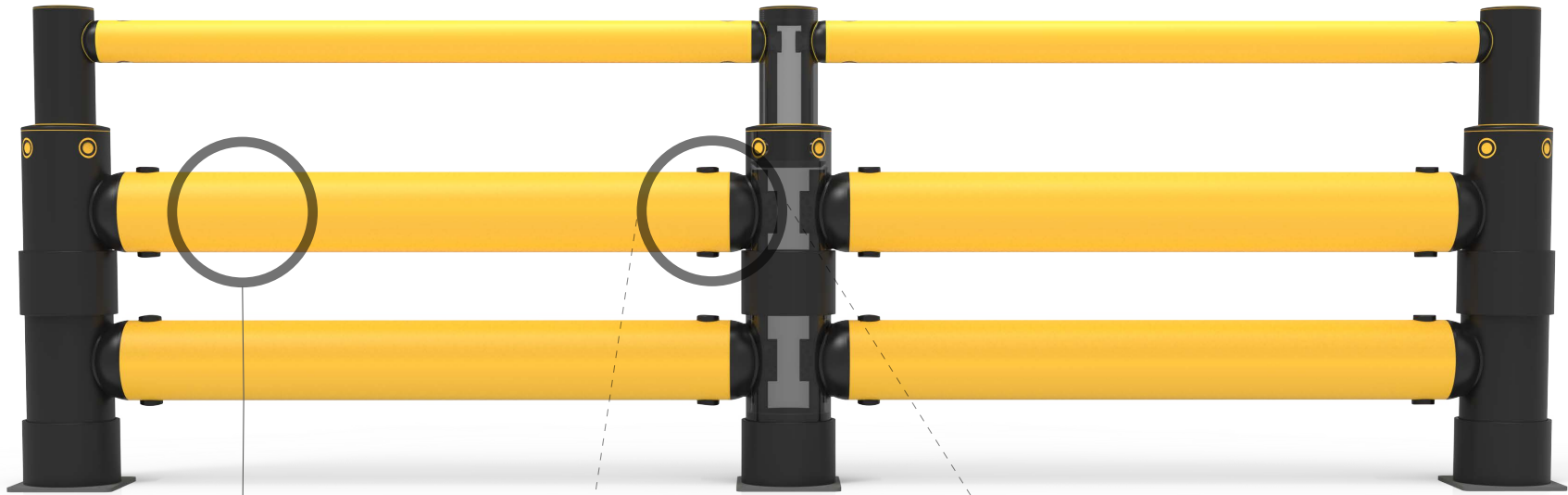

## MEMAPLEX™

Ultimate strength polymer created from an exclusive composition of the most sophisticated polyolefins and rubber additives, expertly blended for unequalled strength and flexibility.

Advanced Engineering Molecular reorientation during manufacturing creates a unique built-in memory that enables the guardrail to fully recover following impacts.

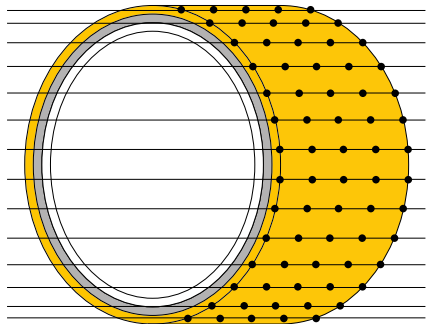

### Revolutionary 3-Layered Material

- Inner strengthening core
- Central impact absorption zone
- Outer UV stabilised colour layer













## Energy Absorption System

A patented 3-phase system that activates sequentially for unparalleled energy absorption.

- 1 Memaplex™ rail flexes to absorb impact, initiating the rail pin to slide forward and transfer load energy to the compression pocket.
- 2 Compression of the pocket continues to disperse energy as the coupling rotates around the post pin to activate further absorption.
- 3 At peak energy, the coupling twists further, engaging the post pin and instigating torsion of the post to dispel remaining forces.

- |                   |                             |
|-------------------|-----------------------------|
| <b>A</b> Post Pin | <b>D</b> Compression Pocket |
| <b>B</b> Coupling | <b>E</b> Rail               |
| <b>C</b> Rail Pin |                             |

## Suitability

Vehicle						Application		<b>8T+</b>				
	Charlotte Airport Baggage Truck	Linde Airport Baggage Truck	Push Back Tug	Unit Load Device	Electric Tow Tractor		Protects structures	Suitable for heavier vehicles	Suitable for busy areas	Protects machinery	Suitable for airports	Suitable for pedestrians



Unrivalled recovery through a unique built-in memory that allows the guardrail to flex, cushion and reform repeatedly upon impact, saving vast amounts in barrier and vehicle repairs.



Huge return on investment from incident prevention and downtime avoidance as guardrails, vehicles, floors and equipment do not need replacing or repair.

## Features and benefits



Multi-directional system ensures a streamlined fit into any operation and the removal of hard angles.



Ultra-low maintenance material is chemical and water resistant, non-corrosive, non-scratch and self coloured so no repainting, rusting, flaking or corrosion.



Exclusive modularity allows rails and posts to be replaced in-situ without removing adjacent guardrail sections.



Seals reduce the risk of water ingress.

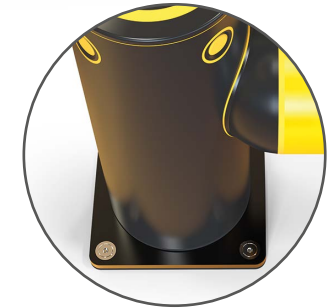

Zinc nickel, electrophoretic coating on base plates as standard, provides advanced protection against corrosion damage.



Self coloured and UV stabilised for continued visibility and long lasting aesthetics with no repainting.



No floor damage 80% of impact force is absorbed, transferring just 20% to the floor.

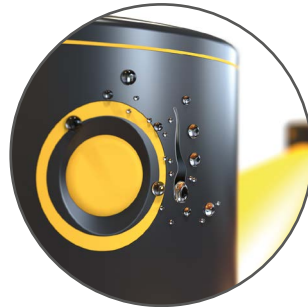

Wipe-clean, water resistant surface.



Ergonomic design with no sharp edges.



Environmentally friendly and 100% recyclable.



