



Heavy Duty ForkGuard Kerb Guardrail

The Heavy Duty ForkGuard kerb barrier provides extreme strength, ground-level protection from impacts and vehicle forks. Ideal for protecting machinery, goods, pedestrian walkways and areas vulnerable to fork penetration, it can be used as a standalone solution or in combination with other A-SAFE safety guardrails.

Quick to install, the Heavy Duty ForkGuard has been engineered to flex and fully recover from heavy impacts – without causing floor damage. The robust polymer profile surfaces are designed to resist and deflect vehicle forks, while a unique internal rail provides the ultimate in strength, stability and form memory, impact after impact.

Huge return on investment from incident prevention and downtime avoidance as guardrails, vehicles, floors and equipment do not need replacing or repair.

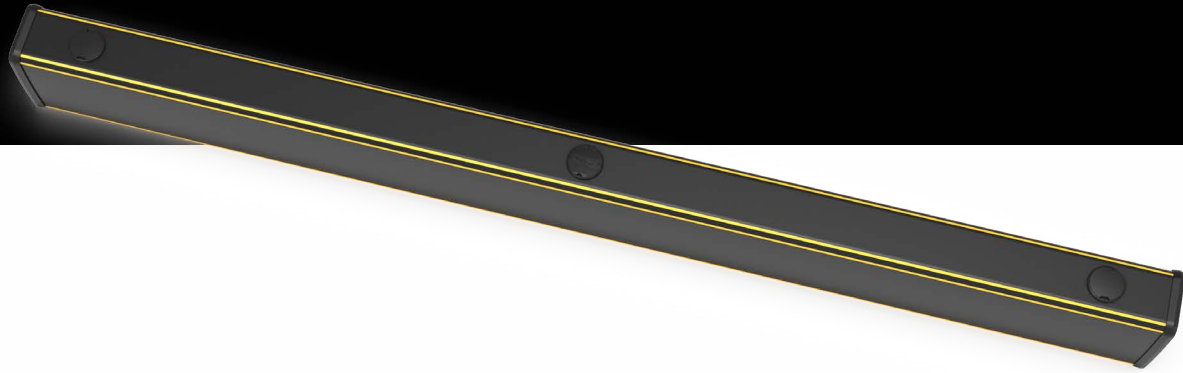

Engineered design optimises the surface for impact recovery. Tapering at the top provides enhanced deflection to create a spring effect. Rounded corners remove stress, preserving parts that are susceptible to snapping.

Features and benefits

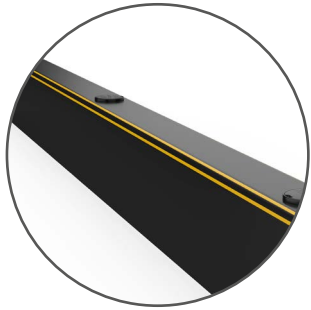

Ultra-low maintenance material is chemical- and water-resistant. It is also non-corroding, non-scratch and self-colored, eliminating the need for painting.



Energy-absorbing support rail increases the overall strength of the ForkGuard, while also enhancing recovery after impact.



Strengthened fixings and custom spacers prevent dissipated impact energy from pulling up fixings or damaging floors.



No floor damage 80% of impact force is absorbed, transferring just 20% to the floor.



Simple assembly with encapsulating end caps and the A-SAFE logo for clear orientation.

Suitability

Vehicle



Manual Pallet Truck



Electric Pedestrian Stacker



Fork Close Up

Application



Protects against low-level impacts



Protects machinery



Suitable for pedestrians



Technical Information

How the energy from a vehicle impact is calculated

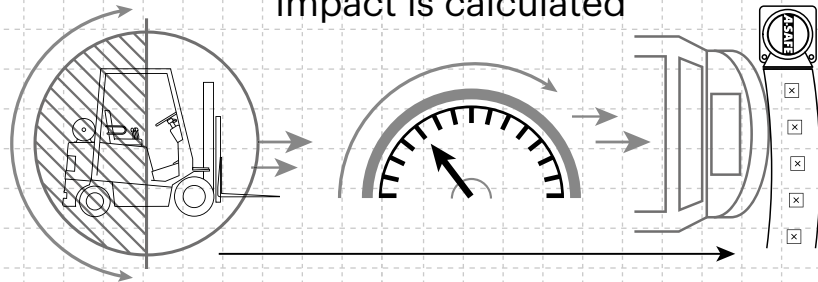

$$\frac{1}{2} \text{ Mass} \times \text{Speed}^2 = \text{Joules}$$

Tested Impact Energy

15,800 Joules

Equivalent vehicle and speed



7 ton X **5 mph**
impact

Mid-kerb 90° Impact
on kerb guardrail

Impact Test

Max Energy (Joules) at 90° **15,800**

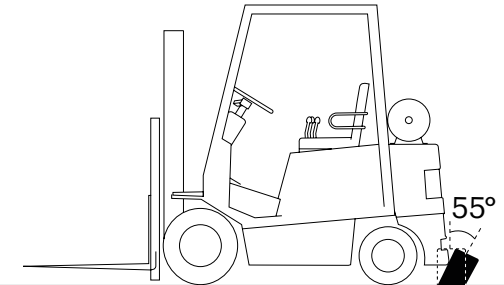

Deflection at max energy
55° Lean

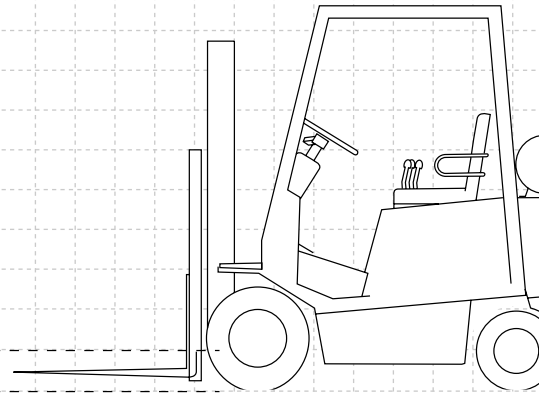
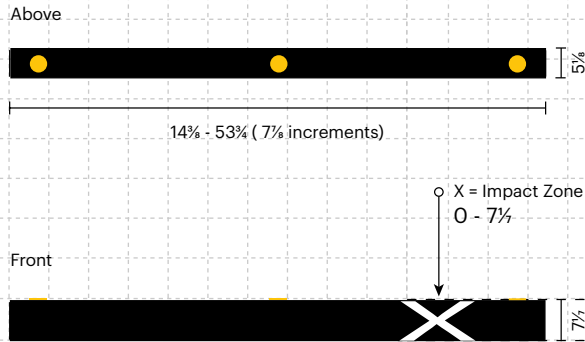

Dimensions (inches)



Colour Combinations

	
Standard black with yellow stripes RAL 9005* PANTONE Black	Standard black with grey stripes RAL 9005* PANTONE Black

*Please note that the RAL and PANTONE colors listed are the closest match to standard A-SAFE colors, but may not be exact matches of the actual product color and should be used for guidance only.

Material Properties	MEMAPLEX™
Temperature Range	-14°F to 122°F
Ignition Temperature	698°F to 734°F
Flash Point	662°F to 698°F
Toxicity	Not Hazardous
Chemical Resistance	Excellent - ISO/TR 10358
Weathering Stability (Grey Scale)	5/5*
Light Stability (Blue Wool Scale)	7/8**
Static Rating (Surface Resistivity)	1015 - 1016 Ω

* Weathering scale 1 is very poor and 5 is excellent
** Light stability scale 1 is very poor and 8 is excellent

