



iFlex Double Traffic Barrier+

Designed to protect people from injury, and safeguard buildings and equipment from damage both inside and out.

The double rail provides maximum resistance and protection from straying vehicles in high-impact areas. This heavy duty, dual-function guardrail separates and guides pedestrians and drivers, whilst also physically defending against heavyweight forces, preventing incidents and accidents. Ideal for high traffic environments where people and larger mass vehicles intermix.



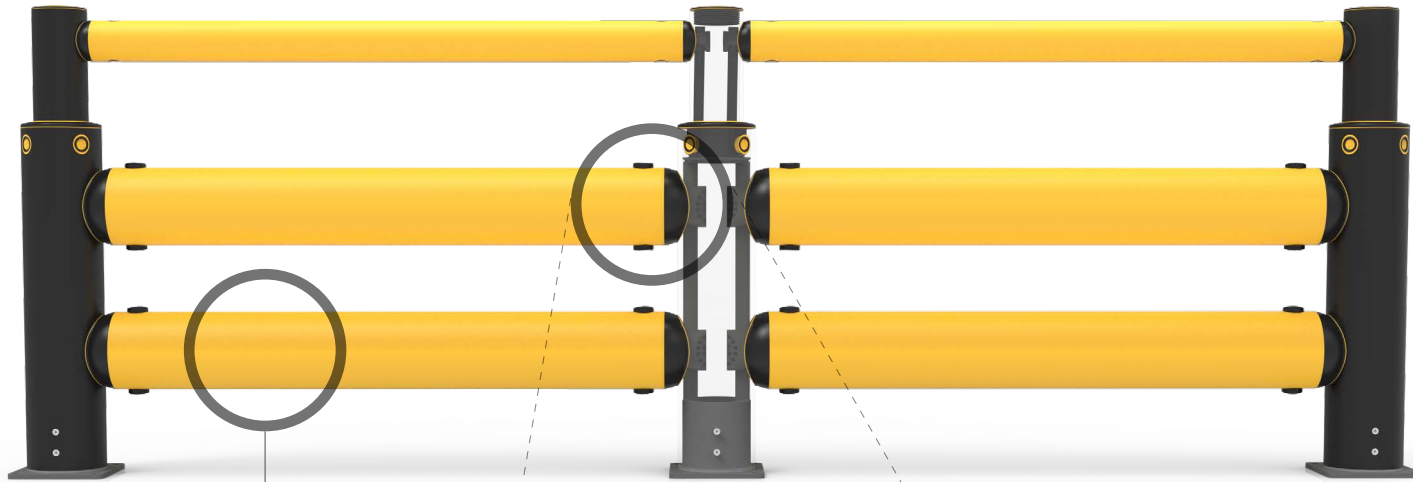

MEMAPLEX™

Ultimate strength polymer

created from an exclusive composition of the most sophisticated polyolefins and rubber additives, expertly blended for unequalled strength and flexibility.

Advanced Engineering Molecular

reorientation during manufacturing creates a unique built-in memory that enables the guardrail to fully recover following impacts.

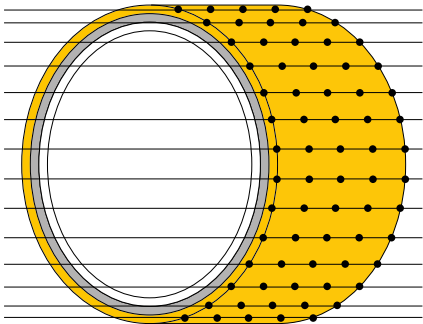

Revolutionary 3-Layered Material

- Inner strengthening core
- Central impact absorption zone
- Outer UV stabilised colour layer



Energy Absorption System

A patented 3-phase system that activates sequentially for unparalleled energy absorption.

- 1 Memaplex™ rail flexes to absorb impact, initiating the rail pin to slide forward and transfer load energy to the compression pocket.
- 2 Compression of the pocket continues to disperse energy as the coupling rotates around the post pin to activate further absorption.
- 3 At peak energy, the coupling twists further, engaging the post pin and instigating torsion of the post to dispel remaining forces.

- | | |
|-------------------|-----------------------------|
| A Post Pin | D Compression Pocket |
| B Coupling | E Rail |
| C Rail Pin | |

Suitability

Vehicle



Engine counterbalance heavy duty FLT



Heavy duty counterbalance FLT



High rack stacker



Electric high reach truck



Electric tow tractor

Application



Protects structures

8T+

Suitable for heavier vehicles



Suitable for busy areas



Protects machinery



Protects Ped



Unrivalled recovery through a unique built-in memory that allows the barrier to flex, cushion and reform repeatedly upon impact, saving vast amounts in guardrail and vehicle repairs.



Huge return on investment from incident prevention and downtime avoidance as guardrails, vehicles, floors and equipment do not need replacing or repair.

Features and benefits



Multi-directional system ensures a streamlined fit into any operation and the removal of hard angles.



Ultra-low maintenance material is chemical and water resistant, non-corrosive, non-scratch and self coloured so no repainting, rusting, flaking or corrosion.



Exclusive modularity allows rails and posts to be replaced in-situ without removing adjacent guardrail sections.



Seals reduce the risk of water ingress.



Zinc nickel, electrophoretic coating on base plates as standard, provides advanced protection against corrosion damage.



Self coloured and UV stabilised for continued visibility and long lasting aesthetics with no repainting.



No floor damage 80% of impact force is absorbed, transferring just 20% to the floor.

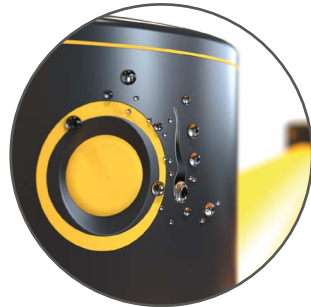

Wipe-clean, water resistant surface.



Ergonomic design with no sharp edges.

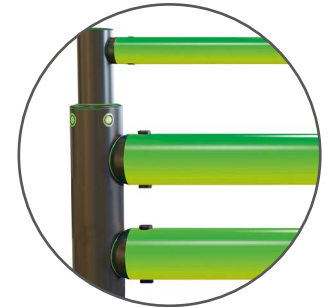

Environmentally friendly and 100% recyclable.



Technical Information

How the energy from a vehicle impact is calculated

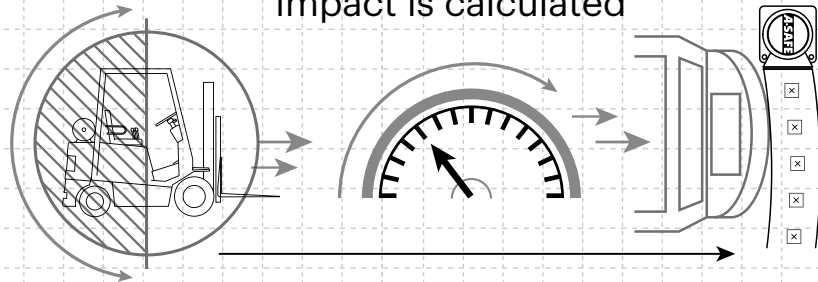

$$\frac{1}{2} \text{ Mass} \times \text{Speed}^2 = \text{Joules}$$

Tested Impact Energy

41,000 Joules

Equivalent vehicle and speed

12.5 ton X **6 mph impact**

Mid Rail 45° Impact on 78% Post Centres

Dimensions (mm)

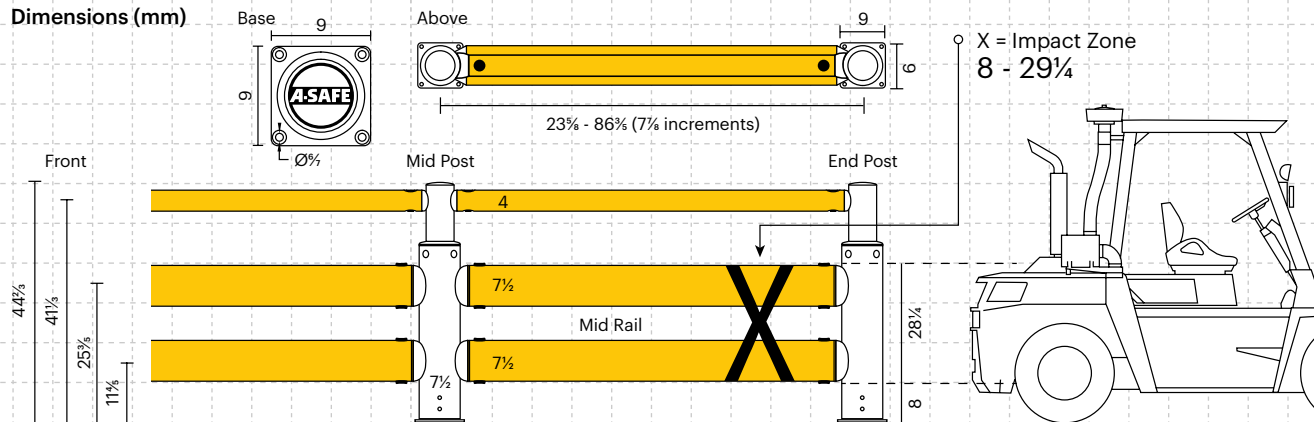

Impact Test	Impact Angle on 78% Post Centres			
	90°	67.5°	45°	22.5°
Mid Rail Max Energy (Joules)	20,500	24,017	41,000	139,983

End Post Max Energy (Joules) - 90°	6,900
Mid Post Max Energy (Joules) - 90°	6,900

Deflection at Max Energy 15 inches

Force to Bolt 34kN

Material Properties	MEMAPLEX™
Temperature Range	14°F to 122°F
Ignition Temperature	698°F to 734°F
Flash Point	662°F to 698°F
Toxicity	Not Hazardous
Chemical Resistance	Excellent - ISO/TR 10358
Weathering Stability (Grey Scale)	5/5*
Light Stability (Blue Wool Scale)	7/8**
Static Rating (Surface Resistivity)	1015 - 1016 Ω

Post Options

	Standard Black RAL 9005* PANTONE Black		Standard Yellow RAL 1007* PANTONE 7548*
--	--	--	---

Rail Options

Standard Yellow RAL 1007* PANTONE 7548*	Standard Black RAL 9005* PANTONE Black	Standard Grey RAL 9007* PANTONE Cool Grey 5*

Color Combinations

*Please note that the RAL and PANTONE colors listed are the closest match to standard A-SAFE colors, but may not be exact matches of the actual product color and should be used for guidance only.

* Weathering scale 1 is very poor and 5 is excellent
** Light stability scale 1 is very poor and 8 is excellent

